

Horch 930V

BATTERY POWERED RIDE-ON

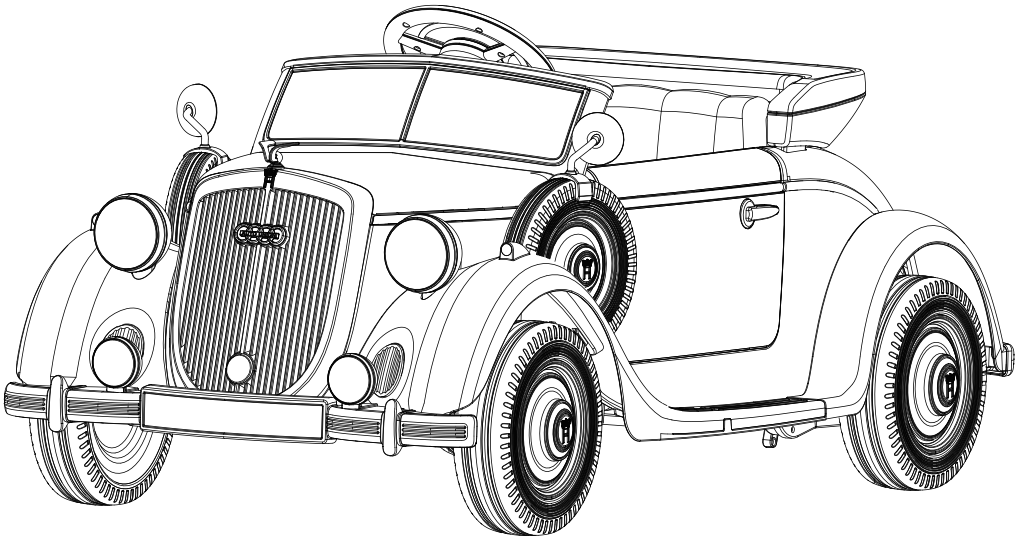

Owner's Manual with Assembly Instructions

Styles and colo(u)rs may vary.
Made in China.

The owner's manual contains important safety information as well as assembly, use and maintenance instructions.

The Ride-on Car must be assembled by an adult who has read and understands the instructions in this manual.

Keep the package away from children and dispose of properly before use.

Keep this manual for future reference.

On the purchase of your new Ride-On.

This ride-on will provide your child with many miles of riding of enjoyment. To help assure you and your rider a safe ride we ask you to please read this manual carefully, and keep it for future reference.

Follow the recommendations in this manual, they are designed to improve the safety and operation of your ride-on car and it's rider.

Horch 930V Electric Ride-on manufactured by Zhejiang Jiajia Ride-on Co.,Ltd. (Address: Xincang Industrial Zone, Xincang Town, Pinghu City, Zhejiang Province, China). Trademarks, design patents and copyrights are used with the approval of the owner AUDI AG. 

SPECIFICATIONS:

Battery	12V10AH*1	24V7AH*1
Charger	12V1000mA	24V500mA or 24V1000mA

Suitable Age: 37-96 months

Load Capacity: 100 kg (including adult weight)

Speed: 3-5 km/h

Size of Car: 135 * 63 * 60 CM

Power Way: Charging type

Charge Time: 8-12 hours

 **WARNING!**

- **CHOKING HAZARD** - Small parts. Not suitable for children under 36 months. The product contains small parts, keep children away when assembling.
- **ADULT ASSEMBLY REQUIRED.**
- Always remove protective material and poly bags and dispose before assembly.
- Protective equipment should be worn. Always wear shoes and sit in the seat when operating the vehicle.
- Only drive on level ground. Never use on the lawn.
- Never leave a child unattended.
- Keep your hands, hair, and clothes away from moving parts.

 **SAFETY**

The following safety hazards may result in serious injury or death:

- Never leave child unattended. Direct adult supervision is required. Always keep child in view when child is in vehicle.
- To reduce the risk of injury, adult supervision is required. Never use in roadways, near motor vehicles, on or near steep inclines or steps, swimming pools or other bodies of water, always wear shoes, and never allow more than 1 rider.
- Never use in unsafe conditions such as snow, rain, loose dirt, mud, sand, or gravel, otherwise may result in an unexpected accident such as tipping over, and could damage the electrical system or battery
- Not to be used in traffic.
- This toy should be used with caution since skill is required to avoid falls or collisions causing injury to the user or third parties.
- This toy is unsuitable for children under 36 months due to its maximum speed; Maximum user weight is 100kg (including adult weight).
- This toy has no brake.

 **BATTERY INFORMATION**

- Non-rechargeable batteries are not to be recharged.
- Rechargeable batteries are to be removed from the toy before being charged.
- Rechargeable batteries are only to be charged under adult supervision.
- Different types of batteries or new and used batteries are not to be mixed.
- Batteries are to be inserted with the correct polarity.
- Exhausted batteries are to be removed from the toy.
- The supply terminals are not to be short-circuited.

Parts Diagram | 3

HINT: Some parts shown are assembled on both sides of vehicle

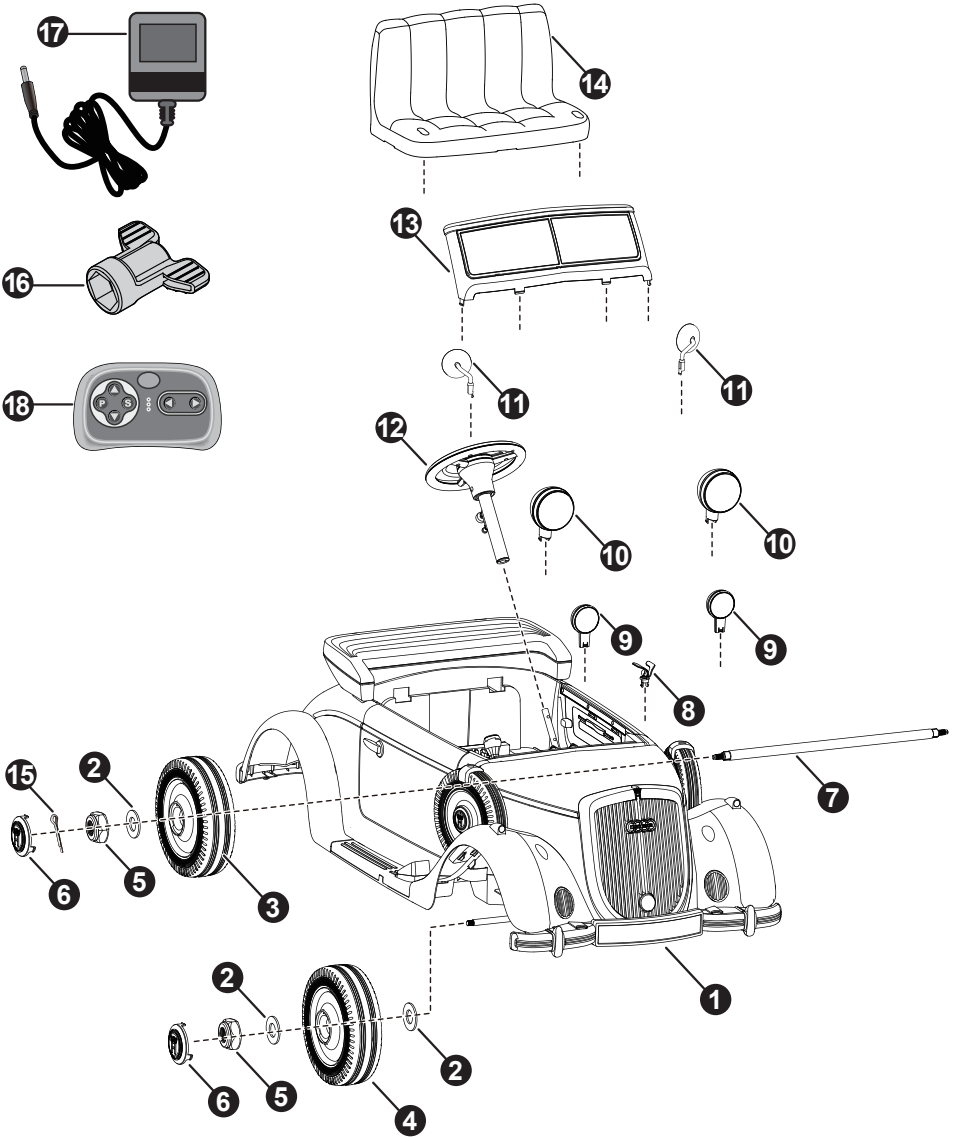

Parts List | 4

PART NO.	PART NAME	Q'ty (pcs)		REMARKS
1	Vehicle body	1		
2	Ø12 washer	6		
3	Rear wheel	2		
4	Front wheel	2		
5	Lock nut	4		
6	Hubcap	4		
7	Rear axle	1		
8	Horch hood emblem	1		
9	Fog light	2		
10	Headlights	2		
11	Side mirror	2		Left and right
12	Steering wheel	1		
13	Windshield	1		
14	Seat	1		
15	Split pin	2		For the rear wheels
16	Spanner	2		
17	Charger	1		
18	Remote controller	1		For R/C type only

Assembly tools required (not included):



Screwdriver

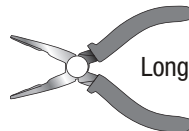

Long nose pliers

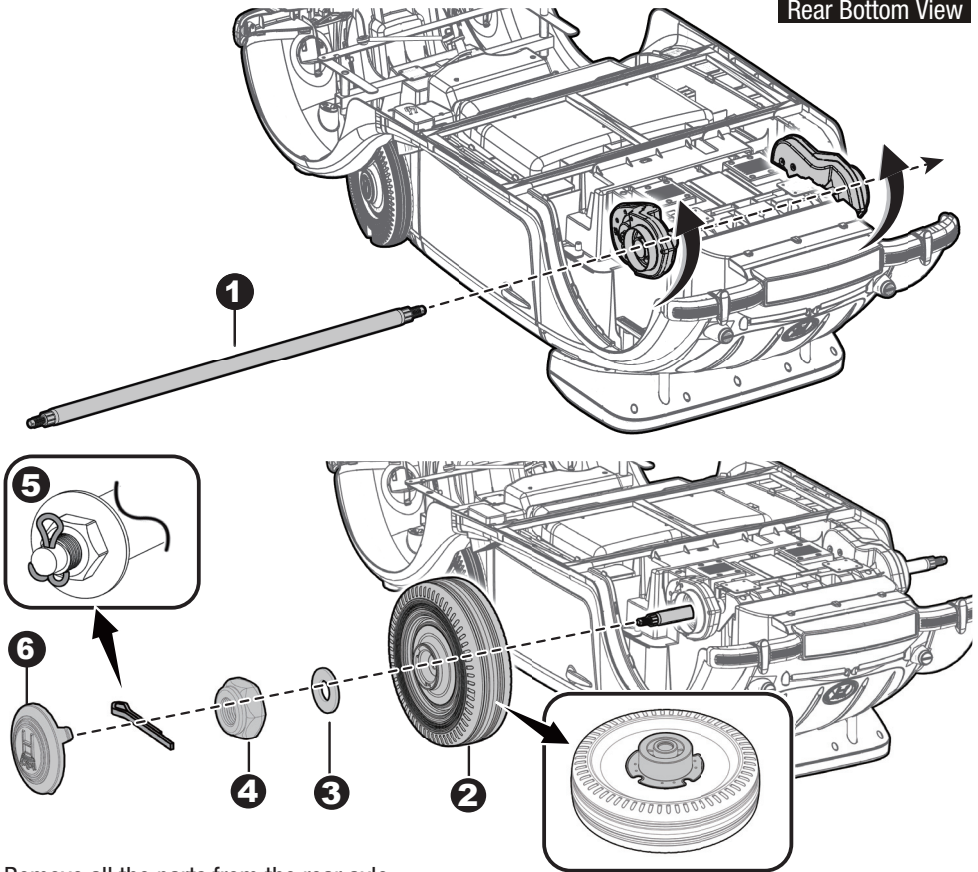

Remove all the parts from the rear axle.

1. Align the holes on the gear box with the holes in the vehicle body, then insert the rear axle through the holes on the gear box and into the hole in the vehicle body, when inserting it half way, lift the another gear box so that the rear axle can go through it and protrude out. Make sure that the rear axle is centered with left and right ends exposed the same distance outside of the vehicle body.

2. Slide the rear wheel onto the rear axle.

3. Slide the $\varnothing 12$ washer onto the rear axle.

4. Tighten a lock nut to the end of the rear axle with a spanner. HINT: An extra spanner has been provided to hold the Lock Nut on the other side of the rear axle while tightening the Lock Nut on the other side.

Repeat the steps 2-4 to assemble the other rear wheel to the rear axle.

5. Insert a split pin into the hole on the each end of the rear axle. Bend the ends of split pins back using a long nose pliers (not included).

6. Fit a wheel cover to each rear wheel.

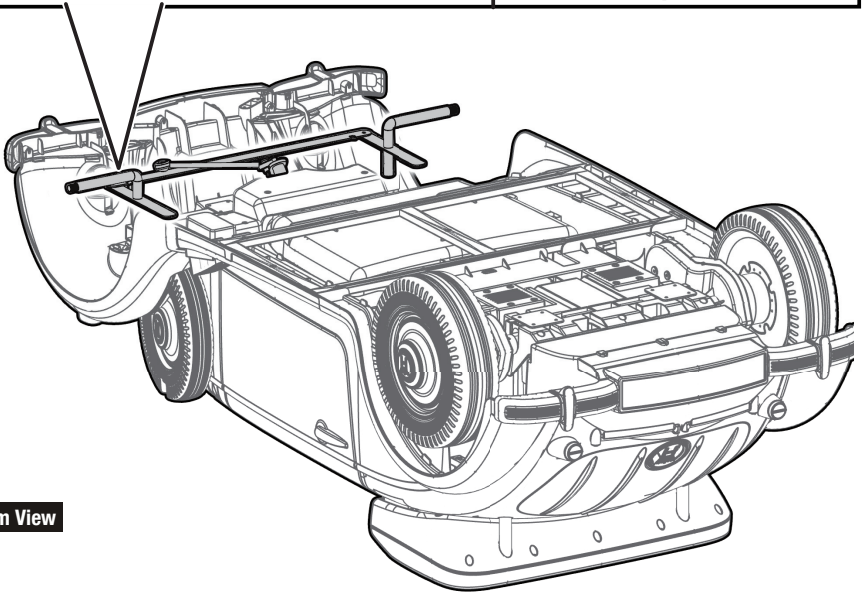
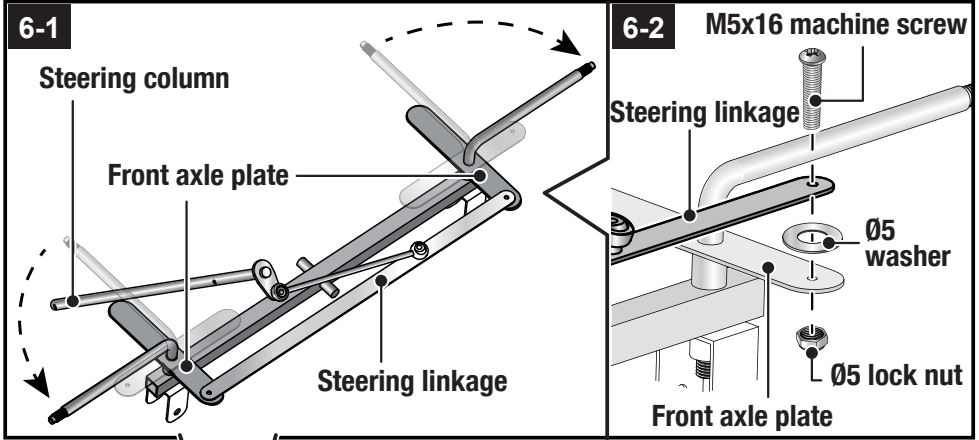

Front Bottom View

Cut off the plastic tie on the front axle with scissors.

6-1. Adjust the front axle plate so that the axle is in the correct position as shown.

6-2. Then insert the M5x16 screw through the hole in the steering linkage, the Ø5 washer and the hole in the front axle plate (ensure the steering linkage sits over the front axle plate as shown), attach the locknut and tighten securely. **DO NOT** over tighten.

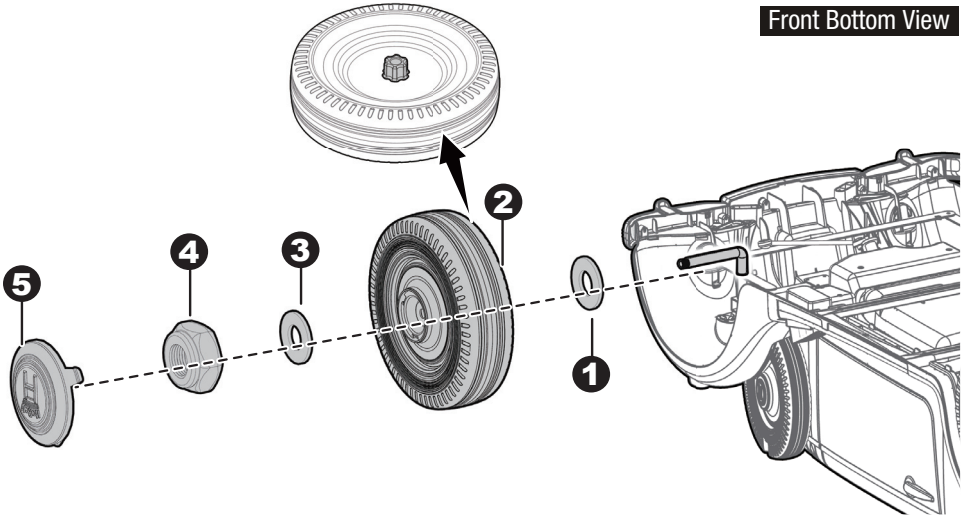

Remove all the parts from the front axle.

1. Slide a $\varnothing 12$ washer onto the front axle.
2. Slide a front wheel onto the front axle.
3. Slide a $\varnothing 12$ washer onto the front axle.
4. Tighten a lock nut to the end of the front axle with a spanner.
5. “Snap” the hubcap to the wheel.

Repeat the above procedure to assemble the other front wheel.

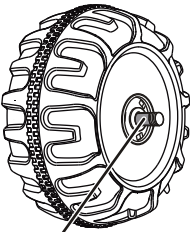

GAP

After assembling any wheel to the axles, please check the gap between the screw thread and the collapsible (refer to below picture), if the gap is too big, please add two or three washers inside the wheel, but after tightening the nut outside the wheel, please turn the wheel by your finger to check if the wheel can run smoothly, this is very important, because if the wheel can run smoothly, it is ok, but if the nut press the wheel and the wheel can't run smoothly, the motor will be broken easily! Then you need to decrease one or two washers to make sure the wheel can run smoothly!

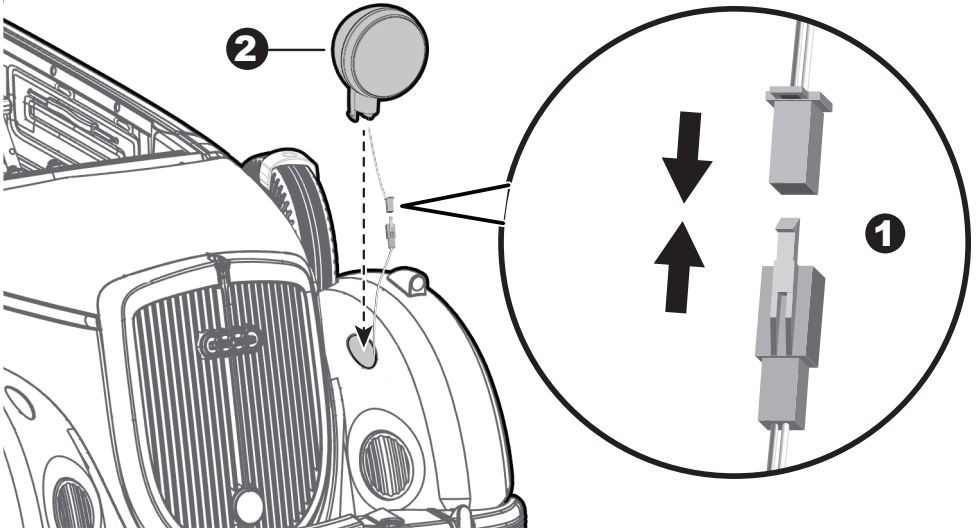

Turn the vehicle body upright.

1. Plug the light connector on the headlight into the connector on the vehicle body,
2. Insert the headlight into the hole on the vehicle body. Repeat for the other headlight.
3. “Snap” the both fog light to the front bumper.
4. “Snap” the horch hood emblem to the bonnet.

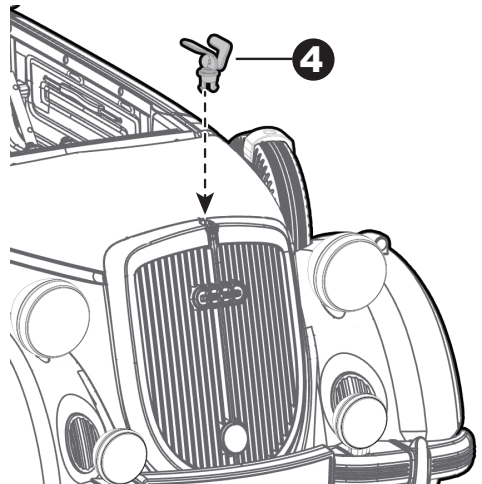
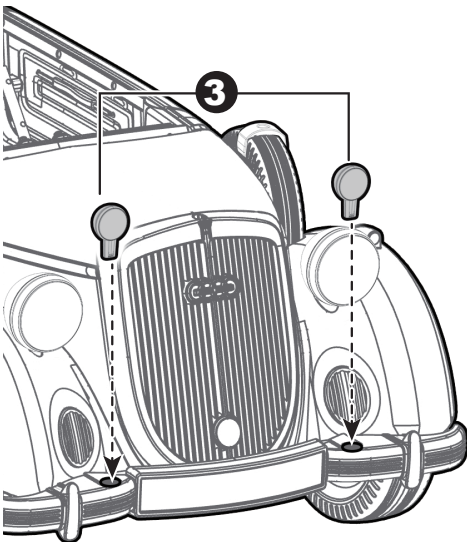

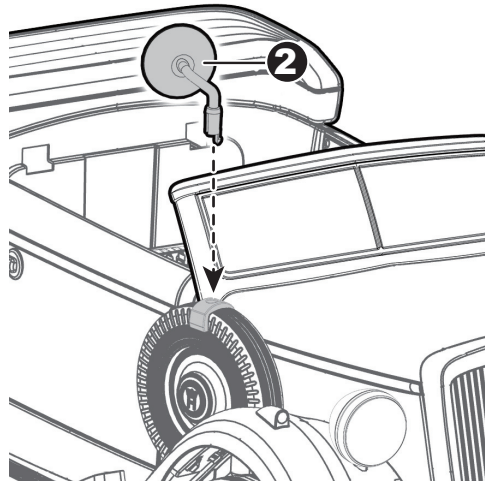
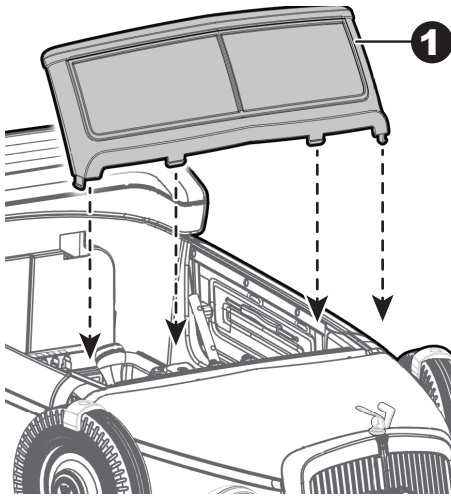

1. Insert the tabs on the windshield into the slots on the vehicle body. Push until it “click” into place.
2. “Snap” the side mirror to side of the vechiel. Repeat for the other side.
- 3-4. Loosen the fastening nut. Pull out the spring pin on the steering wheel and fit the steering wheel onto the end of the steering column. Loosen the spring pin and ensure it clicks into the hole (A or B) on the steering column. Then tigthen the fastening nut.

Tip: The steering wheel is adjustable and has two positions (hole A and hole B) .

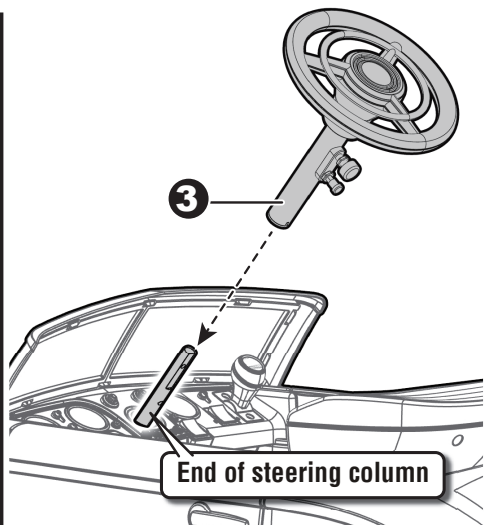
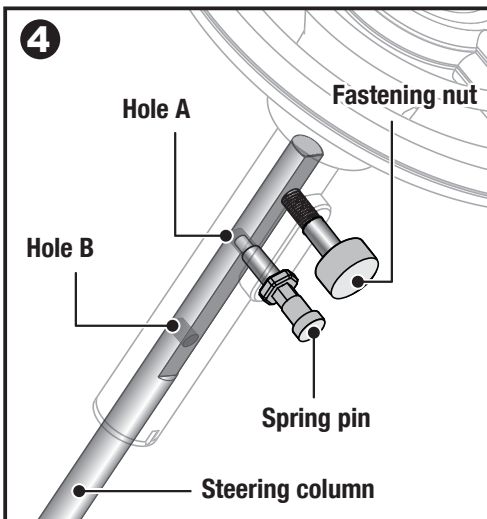

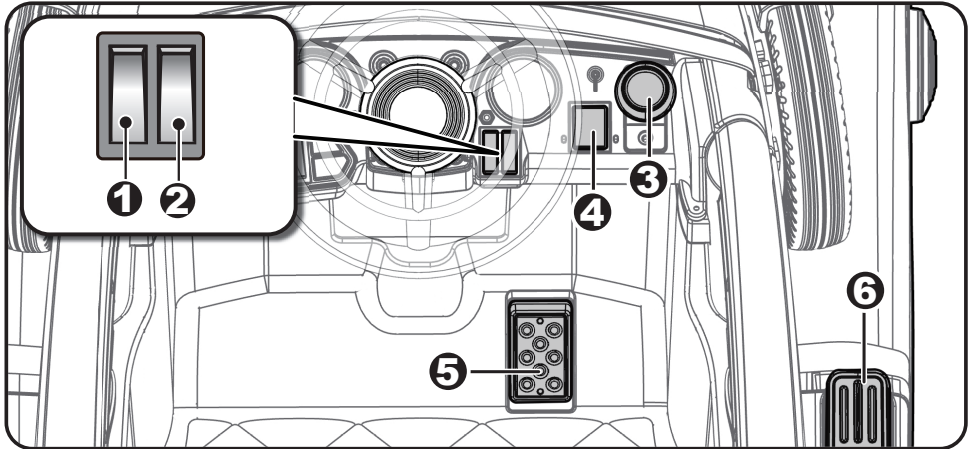

1. Power button: Turns the product on and off.

2. Inner pedal / outer pedal switch:

- Switch to "inner pedal" position, only the inner pedal is allowed to work, and the outer pedal has no effect.
- Switch to "outer pedal" position, only the outer pedal is allowed to work, and the inner pedal has no effect.

HINT: The outer pedal switch is only allowed to be operated by an adult.

3. Forward/reverse switch: Changes the direction that vehicle moves from forward to reverse.

- To move the vehicle forward, shift the lever to top position.
- To move the vehicle backward, shift the lever to down position.

4. High/Low speed switch: Operates the product to move forward in high or low speed.

HINT: The product is designed to operate in low speed only in reverse.

5&6. Inner pedal & Outer pedal: Applies power (speed) to the product.

- To move the product, press the pedal down.
- To brake or slow down, release pressure from the pedal.

HINT: The outer pedal switch is only allowed to be operated by an adult.

⚠ IMPORTANT

- Always stop vehicle when changing the speed or direction to avoid damage the gears and motor.
- **HIGH SPEED:** Make sure your child knows how to steer, how to start and stop the product and knows the rules for safe driving.



Use the vehicle on generally level ground ONLY!

DO NOT Use the vehicle on Lawn space!

⚠ WARNING:

The outer pedal and adult seat are only allowed to be used by an adult.

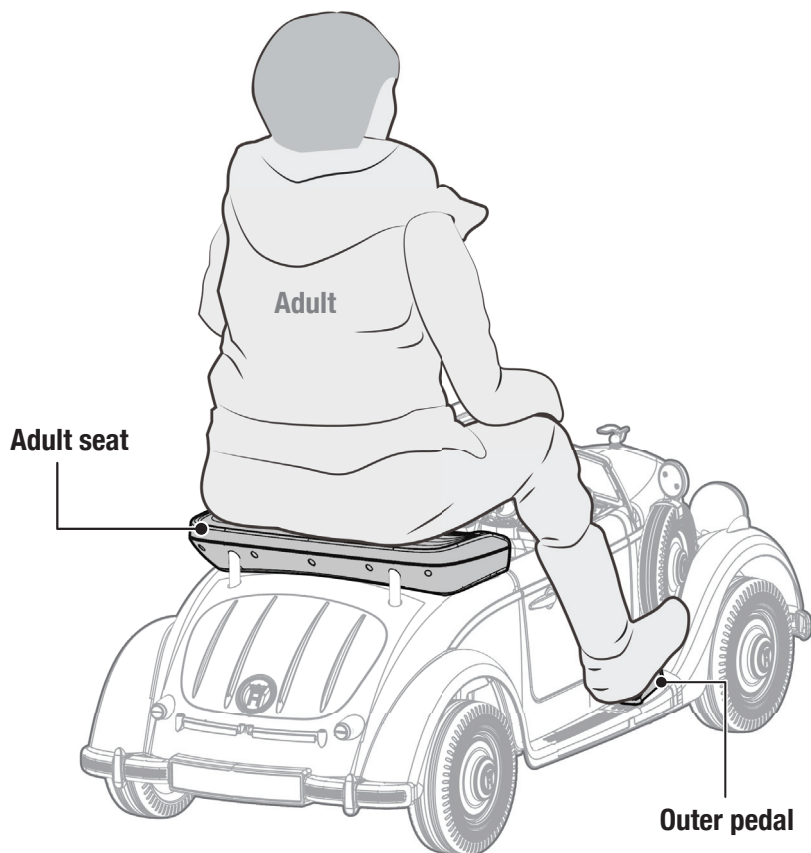

1. The guardian sits on the adult seat.
2. Turn on the power of the product.
3. Turn the “inner pedal / outer pedal switch” to “outer pedal”
4. Use outer pedal to control the movement or stop of the product.

⚠ **WARNING!**

- **ONLY** an adult is allowed charge and recharge the battery!
 - This product with Charging Protection: when charging, all functions will be cut off.
-
- The POWER SWITCH (BUTTON) must be turned in OFF position when charging.
 - Before the first use, you should charge the battery for 4-6 hours. Do not recharge the battery for more than 10 hours to avoid overheating the charger.
 - When the vehicle begins to run slowly, recharge the battery.
 - After each use or once a month minimum recharge time as 8 to 12 hours, less than 20 hours at most.
 - Use the only rechargeable battery and charger supplied with your vehicle. NEVER substitute the battery or the charger with another brand. Using another battery or charger may cause a fire or explosion.
 - Do not use the battery or charger for any other product.
 - If your ride-on with a **Digital voltmeter (IF EQUIPPED)**, the magnitude of voltage will tell you how much power is remaining in the battery when you must recharge the battery. Make sure the vehicle is stop!

12V product	less than 12.5	The battery needs to be charge.
24V product	less than 24	

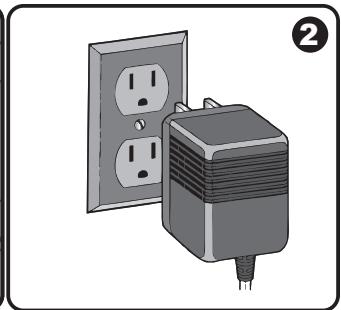
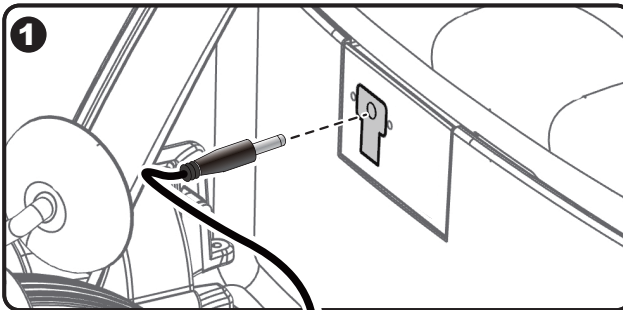

1. Plug the charger port into the input socket (the socket below the seat).
2. Plug the charger plug into a wall outlet. The battery will begin charging.

Battery Disposal



The battery will eventually lose the ability to hold a charge. Depending on the amount of use, and varying conditions, the battery should operate for one to three years.

Important! Recycle the dead battery responsibly. The battery contains lead acid (electrolyte) and must be disposed of properly and legally. It is illegal in most areas to incinerate lead acid batteries or dispose of them in landfills. Take it to a federal or state-approved lead acid battery recycler, such as local automotive battery retailer.

Do not throw the battery away with your regular household waste!

Problem	Possible Cause	Solution
Vehicle does not run	Battery low on power	Recharge battery.
	Thermal fuse has tripped	Reset fuse, see <Fuse>
	Battery connector or wires are loose	Check that the battery connectors are firmly plugged into each other. If wires are loose around the motor contact your distributor please.
	Battery is dead	Replace battery, contact your distributor please.
	Electrical system is damaged	Contact your distributor please.
	Motor is damaged	Contact your distributor please.
Vehicle does not run very long	Battery is under charged	Check that the battery connectors are firmly plugged into each other when recharging
	Battery is old	Replace battery, contact your distributor please.
Vehicle runs sluggishly	Battery low on power	Recharge battery, contact your distributor please.
	Battery is old	Replace battery, contact your distributor please.
	Vehicle is overload	Reduce weight on vehicle.
	Vehicle is being used in harsh conditions	Avoid using vehicle in harsh conditions, see <Safety>.
Vehicle needs a push to go forward	Poor contact of wires or connectors	Check that the battery connectors are firmly plugged into each other. If wires are loose around the motor, contact your distributor please.
	“Dead Spot” on motor	A dead spot means the electric power is not being delivered to the terminal connection and the vehicle needs repair. Contact your distributor please.
Difficult shifting from forward to reverse or vice-versa	Attempting to shift while the vehicle is motion	Completely stop the vehicle and shift, see <Use Your Ride-On>
Loud grinding or clicking noises coming from motor or gear box	Motor or gears are damaged	Contact your distributor please.
Battery will not recharge	Battery connector or adapter connector is loose	Check that the battery connectors are firmly plugged into each other.
	Charger not plugged in	Check that the battery charger is plugged into a working wall outlet.
	Charger is not working	Contact your distributor please.
Charger feels warm when recharging	This is normal and not a cause for concern	

Completely read through this manual and the troubleshooting guide table before calling. If you still need help resolving the problem **Contact your distributor please.**

- It is parents' responsibility to check main parts of the toy before using, Must regularly examine for potential hazard, such as the battery, charge, cable or cord, plug, screws are fastening enclosure of other parts and that in the event of such damage, the toy must not be used until that damage had been properly removed.
- Park the vehicle indoors or cover it with a tarp to protect it from wet weather.
- Recharge the battery after each use. Only an adult can handle the battery. Recharge the battery at least once a month when the vehicle raider is not being used.
- Do not wash the vehicle with a hose. Do not wash the vehicle with soap and water. Do not drive the vehicle in rainy or snowy weather. Water will damage the motor, electric system and battery.
- Clean the vehicle with a soft, dry cloth. To restore shine to plastic parts, use a non-wax furniture polish. Do not use car wax. Do not use abrasive cleaners.
- When not using, all the electrical source should be turn off. Turn off the power switch and disconnect the battery connection.

Fuse

The battery features a thermal fuse with a reset fuse that will automatically trip and cut all power to the vehicle if the motor, electric system or battery is overloaded. The fuse will reset and power will be restored after the unit is turned OFF for 20 seconds and then turned ON again. If the thermal fuse trips repeatedly during normal use, the vehicle may need repair. **Contact your distributor please.**

To avoid losing power, follow these guidelines:

- Do not overload the vehicle.
- Do not tow anything behind the vehicle.
- Do not drive up steep slopes.
- Do not drive into fixed objects, which may cause the wheels to spin, causing the motor to overheat.
- Do not drive in very hot weather, components may overheat.
- Do not allow water or other liquids to come in contact with the battery or other electric components.
- Do not tamper with the electric system. Doing so may create a short, causing the fuse to trip.



RISK OF FIRE. Do not bypass. Replace only with a new fuse.

**Our products are suitable for
ASTM F963; GB6675; EN71 and EN62115 standard.**